

# TRU-RIDE

**MONROE**  
TRUCK EQUIPMENT

## AIR SUSPENSION



**RAM**

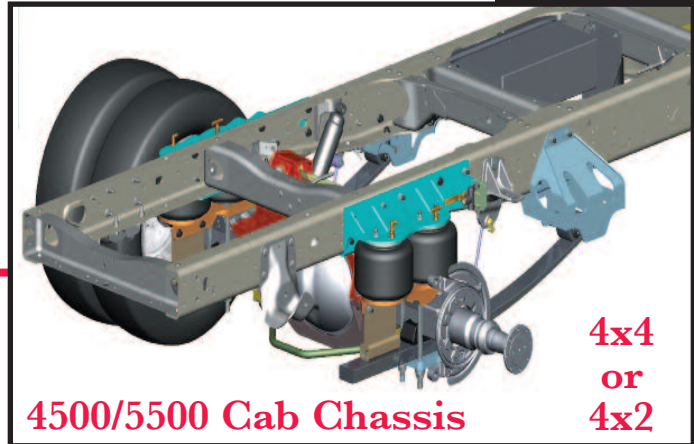

### STANDARD FEATURES

- Rated up to 13,500 Lbs.
- Dual Barksdale Ride Height Valves Provide Level Ride Regardless of Load
- 3-Position Adjustable Shocks Permit Ride Customization
- Lateral Control Device Utilizes a Heavy-Duty Track Rod to Enhance Driving Stability
- (4) 8<sup>1</sup>/<sub>4</sub>" Diameter Air Bags
- Can be Installed Without Re-routing Exhaust System
- Utilizes Rear Factory 1" Diameter Stabilizer Bar Provides Increased Load Stabilization--Improving Handling & Reducing Vehicle Roll. Re-Uses RAM Stabilizer Bar for 5500 and Added for 4500 Chassis.
- Dash-Mounted Low Pressure Warning Light
- Heated Auto Moisture Ejector for Air Tank
- Heavy-Duty, Single Air Compressor Provides a Longer Compressor Life. Installed between Frame Rails on left Side. Must be Installed Outside Frame Rails for Trucks with Mid-Ship Fuel Tank.
- Spring Arm Design Provides a Smoother Ride
- Bracketry is 100% Powder Coated
- Kneel-Function, with In-Cab Ram Dash Switch, Provides Easier Trailer Hookups (*All 4X2 & 4X4 VH Bodies*) and Lowers Chassis on 4X2 & 4X4 Vehicles to Assist Ambulance Manufacturers in Meeting Required Floor Heights. **Lowers Chassis 3" At Rear Axle--BEST IN THE INDUSTRY!**
- Suspension is On-Spot & Insta Chain Ready with Bracket and Holes for Attachment of Chain Assembly

### OPTIONS

- On-Spot or Insta Chain Tire Chains--Utilizes Tru-Ride Suspension Air Compressor, Wired to Factory Switch
- Air Dryer Kit (Strongly Recommended for Trucks Operating in the Snow Belt)
- Air Horns (Requires Additional Air Compressor)
- **MTE Patent-Pending Quick Recovery System--Raises the Fully Dumped Tru-Ride Air Suspension to Normal Ride Height in Less Than 2 Seconds. When Seconds Are Critical!**

Use MTE's RAM  
Ship-Thru Code:  
ZTTN43



**Quick Recovery System**

for **TRU-RIDE**  
MONROE AIR SUSPENSION



**MONROE TRUCK EQUIPMENT**  
1051 W. 7th Street • Monroe, WI 53566  
888-878-8777 • [www.monroetruck.com](http://www.monroetruck.com)

Available for  
Nationwide  
Ship-Thru