

STANDARD FEATURES

- Available for GM 4500/5500, 4X2 Truck with 13.5K Rear Axle
- Lowers Factory Unloaded Frame Height by 4" in the Rear and 2" in the Front
- Dual Ride Height Valves Provide Level Ride Regardless of Load
- 3-Position Adjustable Shocks Permit Ride Customization
- Rear Stabilizer Bar Provides Increased Load Stabilization--Improving Handling & Reducing Vehicle Roll
- Dash-Mounted Air Pressure Gauge
- Heavy-Duty, Single Air Compressor Provides a Longer Compressor Life
- Heated Auto Moisture Ejector for Air Tank
- Spring Arm Design Provides a Smoother Ride
- Bracketry is 100% Power Coated
- Kneel-Function with In-Cab GM Switch Provides Easier Trailer Hookups & Lowers Chassis to Meet Required Ambulance Floor Heights

OPTIONS

- Mount Compressor on the Inside of Frame Rail
- On-Spot Tire Chains--Utilizes Tru-Ride Suspension Air Compressor
- Front Axle Stabilizer Bar Improves Handling & Reduces Vehicle Roll
- Factory Exhaust Relocation--From Right Side to Left Side
- Air Dryer Kit
- Air Horns

SOLOW
AIR SUSPENSION
MONROE TRUCK EQUIPMENT

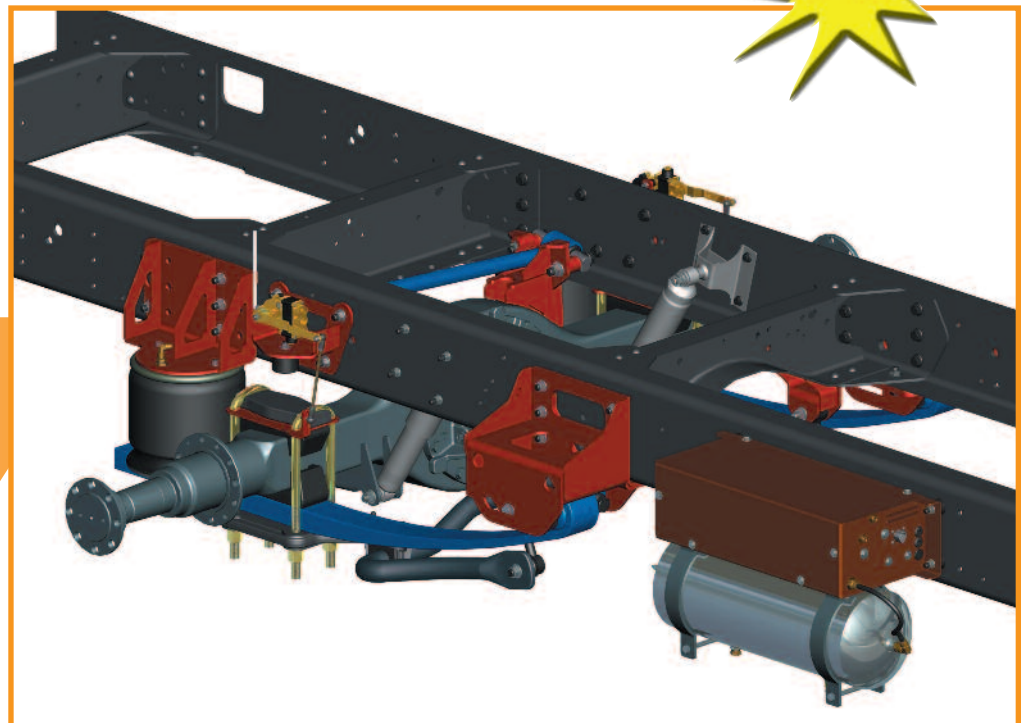

MONROE TRUCK EQUIPMENT
1051 W. 7th Street • Monroe, WI 53566
888-878-8777 • www.monroetruck.com