

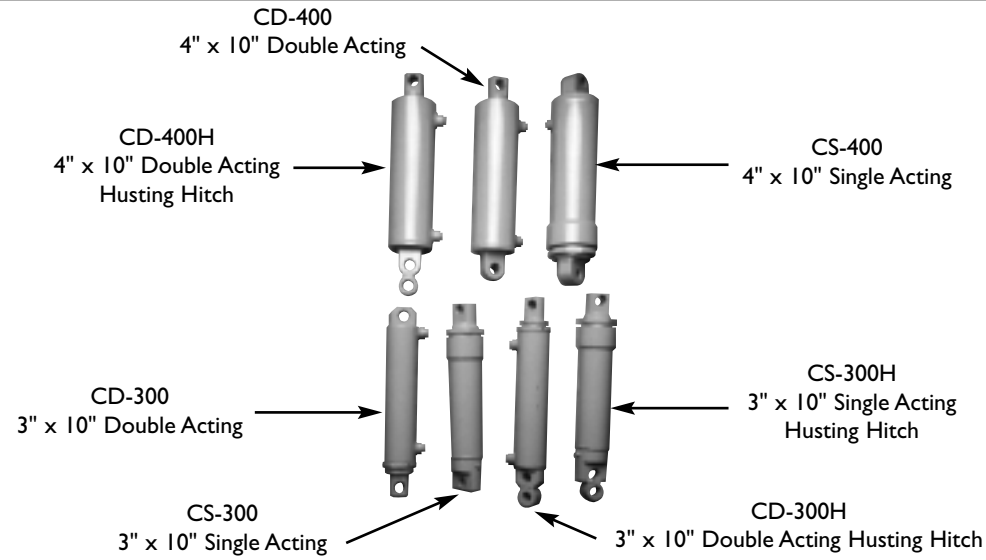

# ACCESSORY OPTIONS

## Lift Cylinders



## Thrust Arm Kits

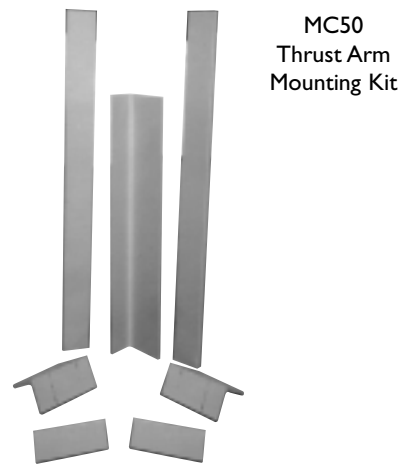

MC50 Thrust Arm Mounting Kit

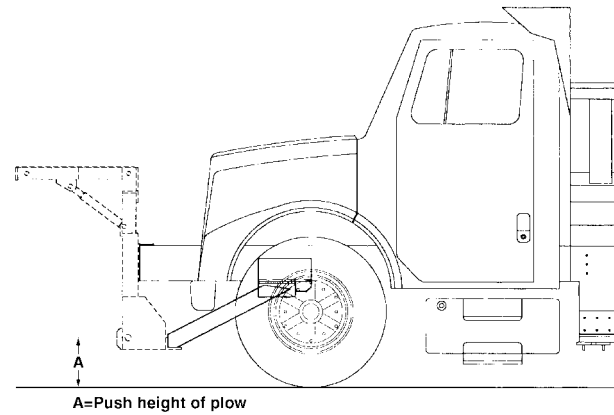

A=Push height of plow

## Side Plates

SPU 1/2" Universal Side Plates

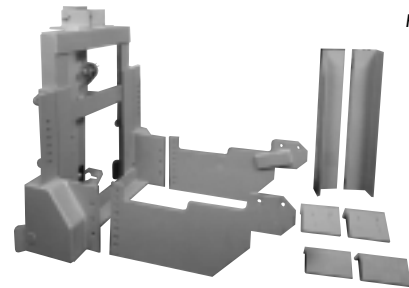

Hitch is not included with the side plates.

SPU-E 1/2" Universal Side Plates for Chassis with Frame Extensions

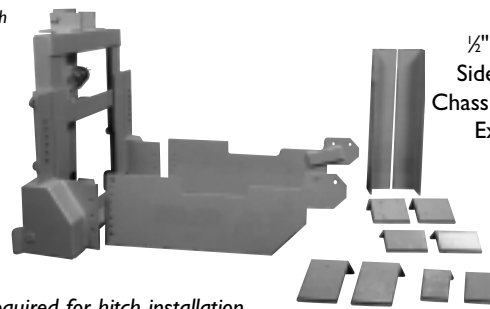

Note: Some modifications may be required for hitch installation.

Product updates and specifications are subject to change without notice.

### Manufactured by:

Monroe Snow & Ice Control  
A Division of Monroe Truck Equipment  
1051 W. 7th Street  
Monroe, WI 53566  
Phone: 800-880-0109  
Fax: 608-328-8390

### Distributed by:

Form HITCH022497



# MONROE QUICK & PIN TYPE HITCHES

## The True One-Man Quick Hitch...

- Safe! Reliable! Heavy Duty!
- Available in Tilt, Torque Arm, or a Lo-Profile Stationary Model
- Accepts a variety of hitch cylinders (Sold Separately)



### TRUCK PORTION:

- Positive 2-point latch system--Will not uncouple
- Adjustable Lift Arm with 3-point chain lift
- 34 1/2" wide--Pushes at truck frame width
- Tapered design jaw boxes allow for horizontal and vertical misalignment when hooking up

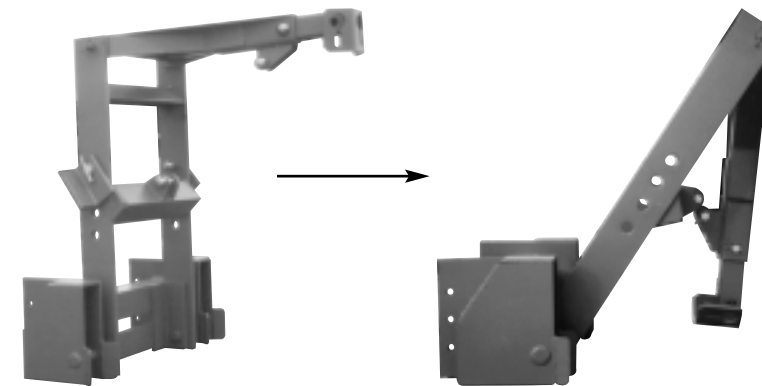

MC7082 Monroe Quick Hitch Truck Portion (Tilt Type)



MC7083 Monroe Quick Hitch Truck Portion (Non-Tilt Type)

### PLOW PORTION:

- Two grease zerks for lubrication
- All moving parts stay with the plow
- Dog latches are hardened steel and adjustable
- Single lever release
- Built in road oscillation

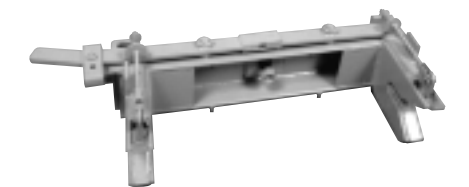

MTE-MC6000 Monroe Quick Hitch Plow Portion

# QUICK HITCHES

## Husting Hitch

000906 29" Truck Portion  
002393 34" Truck Portion



**Husting Hitch**  
29" or 34" width  
2-point latch system  
Direct lift (No lift chains required)  
Single-lever release  
2½" lift ball

**Options**  
½" Universal Side Plate  
Special Lift Cylinder  
Special Hitch Bracing  
Push Arms (MC50 Kit)  
Roller Kit  
Bumper

## Quick Link Hitch

**Note:** A truck portion field conversion kit is available for the quick link application. Model No. QLI-FC

## MC9001--Arrowhead Field Conversion Kit

**Note:** A pin-type truck portion hitch will be needed for conversion kit to function

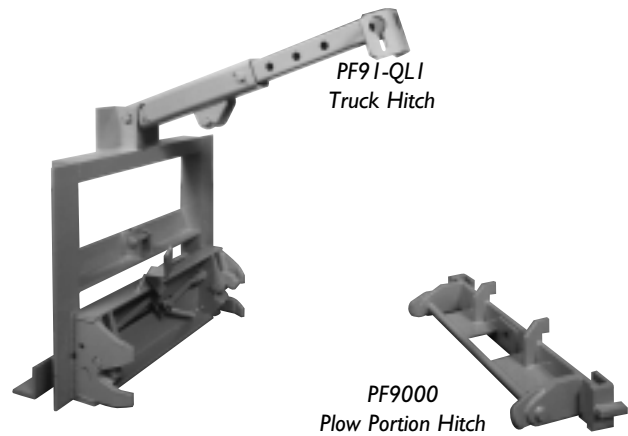

PF91-QLI  
Truck Hitch

PF9000  
Plow Portion Hitch

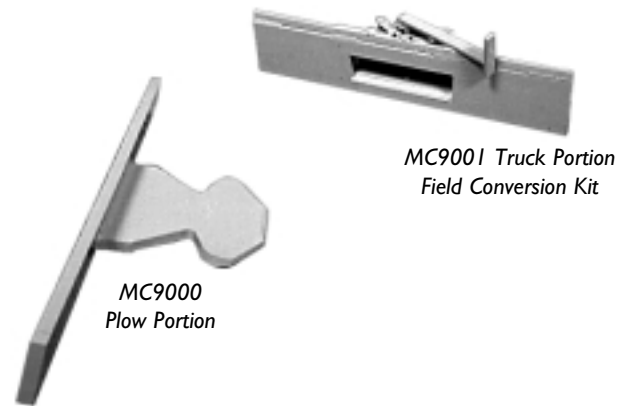

MC9001 Truck Portion  
Field Conversion Kit

MC9000  
Plow Portion

## MC801--Receiver Pin and Loop Field Conversion Kit

**Note:** A pin-type truck portion hitch will be needed for conversion kit to function

## Receiver Latch and Loop Field Conversion Kit

**Note:** A pin-type truck portion hitch will be needed for conversion kit to function

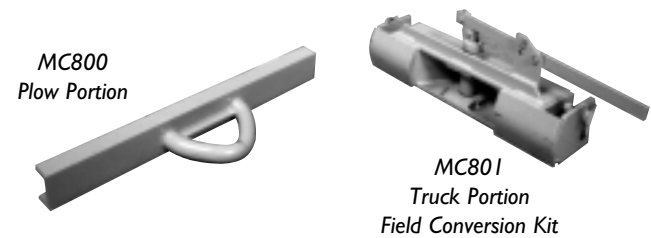

MC800  
Plow Portion

MC801  
Truck Portion  
Field Conversion Kit

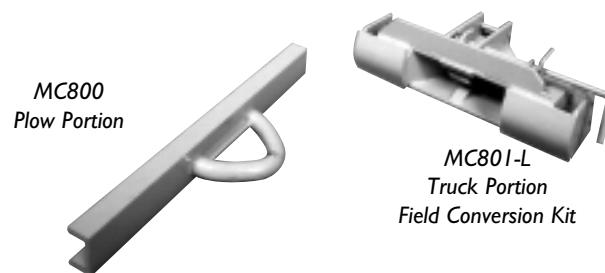

MC800  
Plow Portion

MC801-L  
Truck Portion  
Field Conversion Kit

# PIN-TYPE HITCHES

## MC8000--Universal Pin Hitch with Tilt

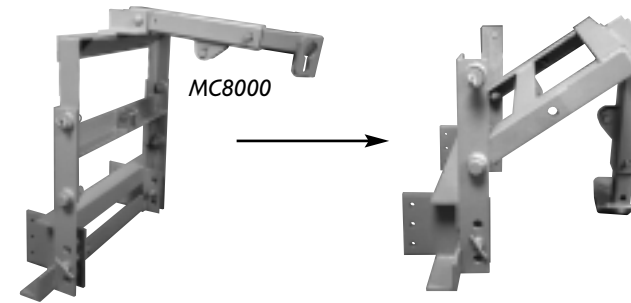

MC8000

## MC5000 Series--Universal Low Profile Stationary (Non-Tilt)

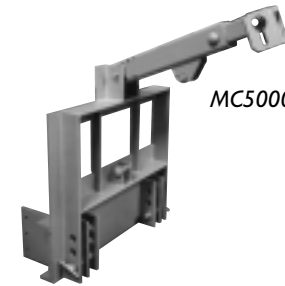

MC5000

## MTA8000-Q Series--Torque Arm, Cylinder Offset for Pump, Monroe Quick Attach Receivers and ½" Side Plates Included with Hitch

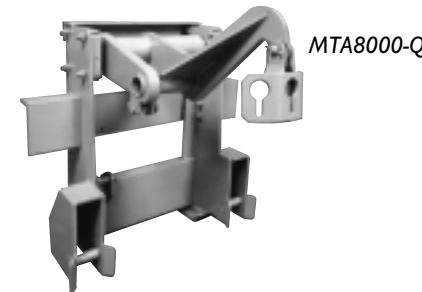

MTA8000-Q

## MC7802--Cheekplate, Non-Tilt Sideplates as Shown with Hitch

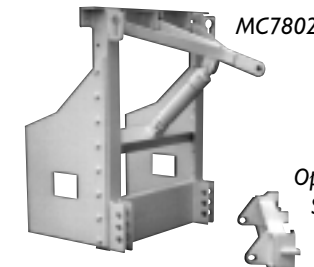

MC7802

Optional Plow Portion  
Swivel Plate Hitch

## MC2075--With Receiver Latch to Accept an MC800 Plow Portion Hitch

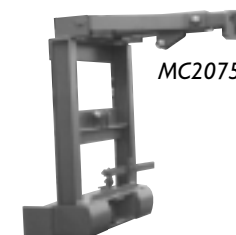

MC2075

## Pin-Type Hitch Features:

- Standard 2-point latch system
- Three vertical hole alignments for proper installation & adjustment
- Simple design with fewer moving parts

## Options include:

- Various Plow Swivel Plates
- Lift Cylinders
- Mounting Kits
- Custom Built Hitches

## MTA8000--Torque Arm, Cylinder Offset for Pump, Pin-type and ½" Side Plates Included with Truck Portion Hitch

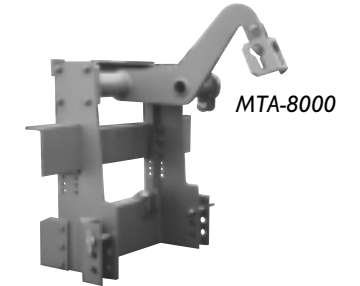

MTA-8000

## MC7801--Tilting, Heavy Duty Bumper to Frame with Pump Mount and ½" Side Plates Included with Hitch

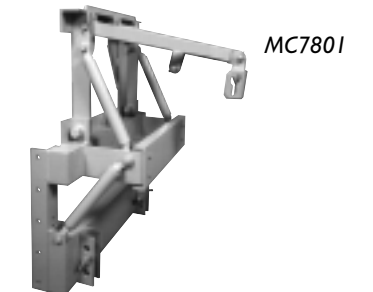

MC7801

## MC200 Series--Heavy Duty, High Profile, Tilt-type, Lever Release

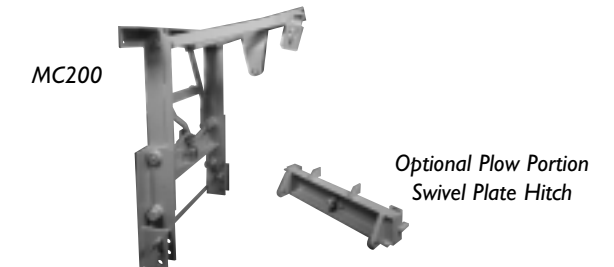

MC200

Optional Plow Portion  
Swivel Plate Hitch

## UBA--Universal Bumper to Axle Hitch

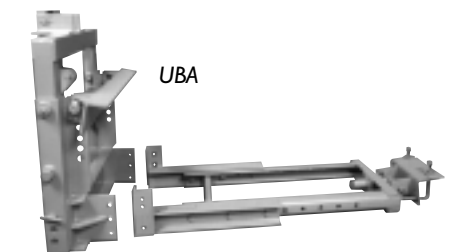

UBA