

MONROE SNOW PLOW



Deep C-Shaped Full Trip Moldboard Height 45" or 55"



Standard Specifications:

- 10 Gauge Roll Formed Moldboard • Six, 1-piece, 1/2" Flame Cut Ribs
- Dual Compression Trip Spring Assemblies
- Two 3" x 10" Double Acting Power Reverse Cylinders with Cushion Valve
- 45" Built-In Monroe Level Lift Assembly; 55" Chain Lift Only
- Stress Proof Machined Pins • Extra Deep Moldboard
- All Hardware Zinc Plated • Moldboard and Pushframe 100% Continuously Welded
- Moldboard Painted Powder Coat Orange • Pushframe Painted Powder Coat Black
- 14" Push Height • Available in 11' & 12' Lengths

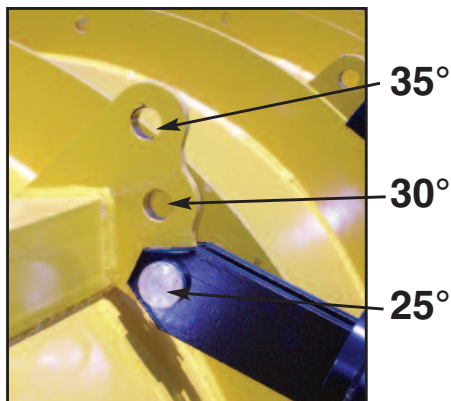
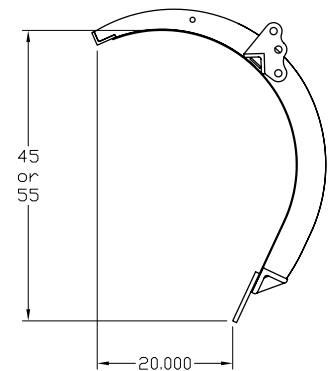

Simple Three Position Adjustment for
Plow Cutting Edge Attack Angle

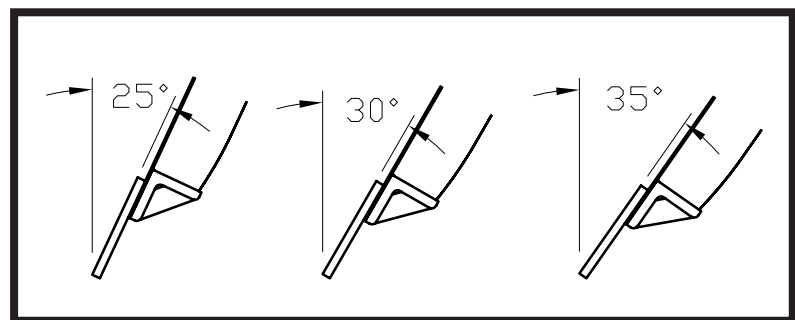

Force Required to Trip Moldboard

LIGHT
TRIP

MEDIUM
TRIP

HARD
TRIP

CAUTION: Plow weight, mounting distance from axle, hitch type and weight, and other additional equipment mounted on the front of a truck will require heavier truck GAWR (Gross Axle Weight Ratings). Contact chassis manufacturer for exact GAWR requirements for your specific equipment.

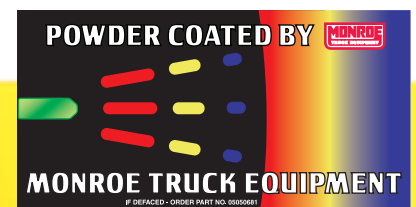

MONROE SNOW PLOW



Deep C-Shaped Slotted Trip Reversible Height 45" or 55"

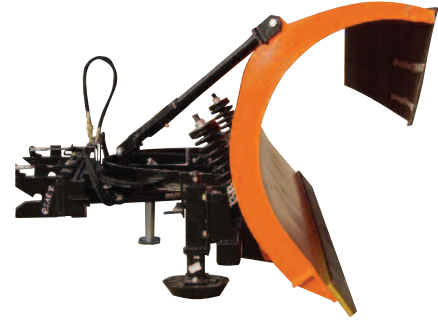
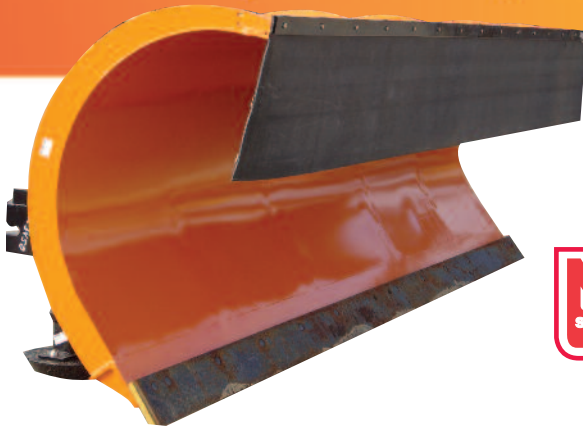

Standard Features:

10ga. Roll Formed Moldboard • Flame Cut Ribs • 2" x 3" x 3/8" Top Angle • 4" x 6" x 1/2" Bottom Angle
Horizontal Moldboard Angle Bracing • (2) Slotted Trip Assemblies with Compression Springs for Moldboard Trip
(4) Slide Assemblies • Dual Adjustable Telescopic Stabilizer Arms with Shear Pins • 2 Slide Rollers
35° Moldboard Attack Angle • (2) Chain Lift • (2) 3" x 10" Double Acting Reverse Cylinders with Cushion Valve
5/8" x 8" C1080 Top Punched Cutting Edge • Moldboard and Pushframe 100% Powder Coat Finish
Screw Adjustable Mushroom Shoes • 14" Push Height • Available in 11' & 12' Lengths

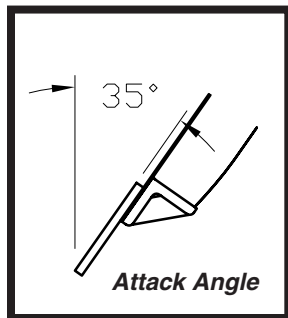

Attack Angle

Dual Adjustable Telescopic Stabilizer Arms

Optional MC6000

Compression Springs for Moldboard Trip

Optional Rubber Snow Deflector

Screw Adjustable Mushroom Shoes

Options:

- Rubber Snow Deflector
- Wrap Around Curb Guards
- Flexible Plastic or Cable Markers
- Adjustable Parking Jack
- Moldboard Shoes
- 3/4" x 6" Carbide Cutting Edge
- 4" Reversing Cylinders
- Polymer Moldboard over Steel
- Skid Shoes, Steel Casters

CAUTION: Plow weight, mounting distance from axle, hitch type and weight, and other additional equipment mounted on the front of a truck will require heavier truck GAWR (Gross Axle Weight Ratings). Contact chassis manufacturer for exact GAWR requirements for your specific equipment.

